

# HAM TIPS



A PUBLICATION OF THE TUBE DEPARTMENT · RCA · HARRISON, N. J.

Volume X, No. 4

Winter, 1950-'51

## 300-Watt Modulator with 811-A Push-Pull Output

By

George E. Jones, Jr., W2CBL\*

HERE is a speech amplifier and modulator capable of delivering 300 watts of audio power through a multi-match modulation transformer into a wide range of class C loads. This unit is especially suitable for use with a transmitter such as the 500-watt rig which was designed by the author and described in a previous issue of HAM TIPS.\*\*

The 811-A modulators are operated at zero bias and a plate voltage of 1250 volts. A 400-volt, 180-milliampere supply for the speech amplifier is included on the modulator chassis.

### Circuit Considerations

A circuit diagram for the modulator is given in Fig. 1. The 6SJ7 amplifier stage is a high-gain stage (gain of approximately 180) designed to operate from the output of a high-impedance crystal or dynamic microphone. The input network ( $R_1, C_1$ ) has been designed to eliminate rf feedback, a difficulty often experienced when high-voltage rf fields are present. This network attenuates any rf voltage picked up in the input circuit before it reaches the grid of the 6SJ7.

One half of the first 6SN7 tube is used as an amplifier directly coupled to the second half of the tube, which is used for phase inversion, to obtain a push-pull signal for the following 6SN7. The cathode and plate resistors,  $R_{10}$  and  $R_{12}$ , respectively, should be matched resistors. The direct-coupled amplifier and the phase-inverter circuit is an adaptation of the well-known "Williamson Circuit." The second 6SN7 is a push-pull amplifier for driving push-pull, triode-connected, class A 807 drivers. The plate resistors  $R_{17}$  and  $R_{18}$ , in the push-pull 6SN7 stage, must be matched resistors to insure a balanced signal in the push-pull stages. Resistors having a tolerance of 5 per cent (gold band) are used for  $R_{10}$ ,  $R_{12}$ ,  $R_{17}$ , and  $R_{18}$ . For all other resistors, a tolerance of  $\pm 10$  per cent (silver band) is satisfactory.

### Construction

The unit is constructed on a conventional 2 by 13 by 17-inch chassis and utilizes a  $10\frac{1}{2}$  by 19-inch rack-mounting front panel. Layout of the parts

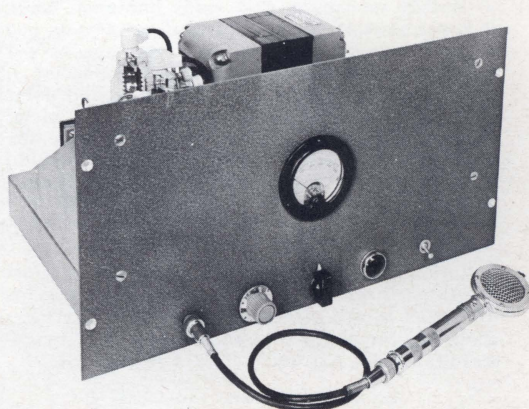

is shown in the photographs. For operating convenience, all the necessary controls are located on the front panel. From left to right, in the above photograph, are shown the microphone input connector, the gain control  $R_7$ , the cw-phone control switch  $SW_2$ , the power indicating pilot

### TVI BIBLIOGRAPHY

Although it is generally agreed that TVI is a problem that will ultimately confront every amateur, most of us are inclined to avoid the subject until we are faced with a specific complaint. The bibliography of articles on TVI on page 3 has been compiled to assist you in overcoming that apparently formidable obstacle to the continued enjoyment of operating your amateur station.

The listed articles contain many suggestions of value to the amateur who is planning to build a new transmitter. The probability of interference can be reduced appreciably if the transmitter design incorporates the recommended precautions to prevent the generation of spurious radiations. From the practical viewpoint, this approach is logical because it requires less effort than is needed for the application of elaborate corrective measures after the transmitter is built.

\*RCA Tube Dept., Harrison, N.J.

\*\*May-August, 1948 (Vol. 8, No. 2)

light PL<sub>1</sub>, and the power-supply on-off switch SW<sub>1</sub>. Meter M<sub>1</sub> is mounted in the center of the panel and is wired into the center tap of the transformer which supplies the 811-A filament power. The meter is placed at ground potential and indicates tube current (total grid and plate current) of the modulator tubes. The front panel and all controls are at ground potential for safety reasons.

The chassis layout is shown in Fig. 2. The power-supply components, viewed from above, are grouped at the upper left-hand side; the modulation transformer is mounted directly behind this supply. The speech amplifier starts at the upper right-hand side and continues to the rear of the chassis. This layout provides a very short, direct input connection to the speech amplifier, and isolates the high-gain amplifier stages from the power supply and modulator output transformer.

Wiring is simple and the 2-inch-deep chassis, shown in Fig. 3, provides easy access for wiring and soldering all components. The layout was chosen to minimize the possibility of oscillation, "motor boating," or hum pickup; lead dressing and placement of parts are not critical. In order to obtain maximum gain with minimum hum, it is necessary to tie the ac and dc returns to one common ground point in the first stage of the speech amplifier. Microphone cable connector J<sub>1</sub> should be connected to the common ground point instead of being grounded directly to the metal chassis. This jack should be insulated from the chassis, and the input wiring of the 6SJ7 should be kept as short as possible to avoid extraneous pickup.

**Adjustment and Operation**

Variable resistor R<sub>29</sub> in the power supply, just ahead of filter capacitor C<sub>4</sub>, should be set for 400 volts at the output end of the second filter choke L<sub>2</sub>. Ample decoupling is provided by capacitors C<sub>4</sub>, C<sub>8</sub>, C<sub>9</sub>, and C<sub>11</sub>, and resistors R<sub>6</sub>, R<sub>9</sub>,

and R<sub>13</sub> to minimize interstage coupling which could result in motor boating.

The 807 push-pull, triode-connected class A stage has a potentiometer (R<sub>20</sub> accessible at the rear of the chassis) in the cathode circuit for balancing the plate currents of the two tubes. This adjustment is made at static (zero signal) conditions, and, once set, need not be changed unless the 807 tubes are changed. Test measurements on the completed speech amplifier show that positive grid current begins to flow in the second 6SN7 and the 807's at the same input-signal level, so the values of biasing resistors for the various stages are nearly optimum. In operation, the 811-A milliammeter will indicate about 125 ma on the peak swings of normal speech when the 1250-volt plate supply is off. When the plate supply is on, this current increases to approximately 450 ma on voice peaks for full output. With a sine-wave signal input, the 811-A's deliver approximately 300 watts into a fixed resistance load before the amplifier is overdriven (as evidenced by flattening of the sine-wave output voltage).

The driver transformer, T<sub>1</sub>, is connected to obtain the maximum step-down ratio (primary-to-secondary) to provide for ample drive to the 811-A grids and also good regulation of the grid voltage for the class B stage.

The terminals on the multi-match transformer T<sub>2</sub>, in the output, are connected so that the 9200-ohm, plate-to-plate load of the 811-A's is matched to the approximately 4000-ohm load of an 812-A push-pull, class C amplifier.

A suggested connection for the cw-phone control switch SW<sub>2</sub> is shown in Fig. 1 with dotted-in connections to the class B and class C plate power-supply relays.

The amplifier is stable at full setting of the gain control. The frequency response characteristic of the amplifier and modulator is flat from 100 to 7,000 cps; it drops off only slightly from 7,000 to 10,000 cps.

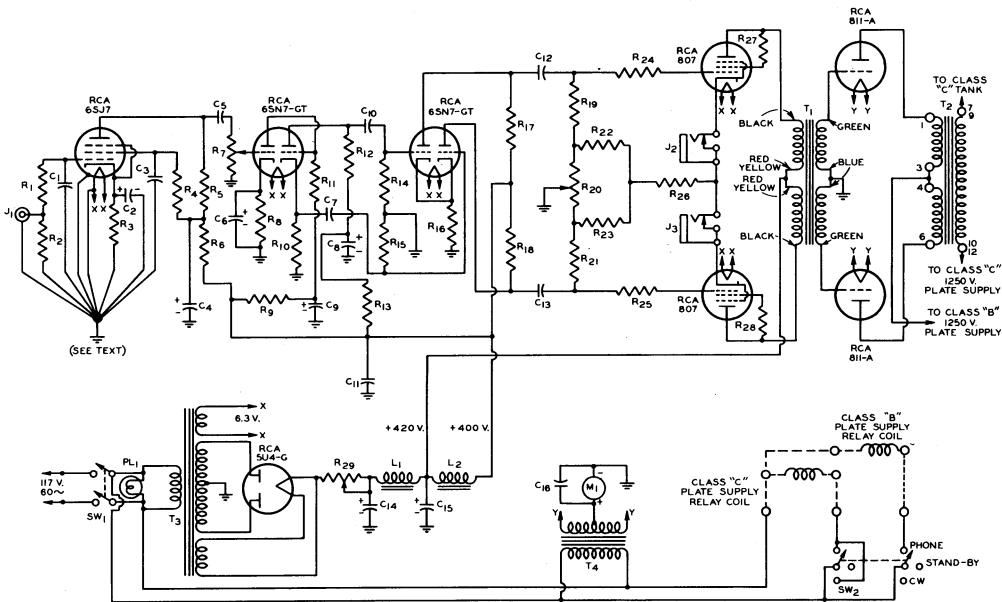

Fig. 1. Schematic diagram of the 300-watt modulator, speech amplifier, and power supply.

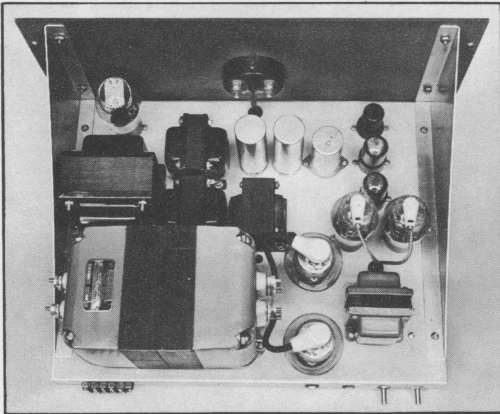

Fig. 2. Top view of the modulator; note that the well-planned layout of the modulator components permits the inclusion of a husky power supply on the same chassis.

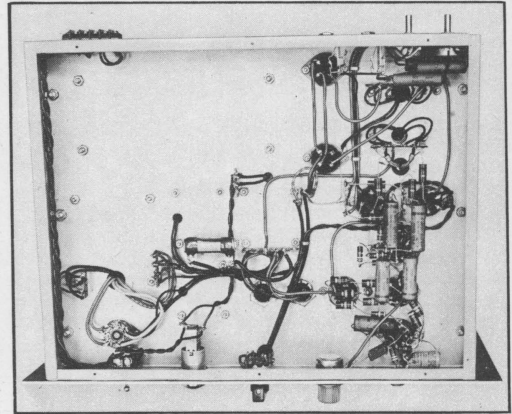

Fig. 3. Bottom view of the modulator; accent on simplicity and accessibility! Excellent performance, and no hum or feedback, without special dressing of leads or shielding!

### PARTS LIST

- |   |  |                                   |   |
|---|--|-----------------------------------|---|
| C <sub>1</sub>  | 0.0005 $\mu$ f, mica, 600 v.                                       | R <sub>10</sub> & R <sub>12</sub> | 22,000 ohms, 1 watt (matched).  |
| C <sub>2</sub>  | 4 $\mu$ f, electrolytic, 25 v.                                     | R <sub>13</sub>                   | 22,000 ohms, 1 watt.  |
| C <sub>3</sub> , C <sub>7</sub> , C <sub>10</sub> , C <sub>12</sub> & C <sub>13</sub> | 0.1 $\mu$ f, paper, 600 v.   | R <sub>16</sub>                   | 820 ohms, 1 watt.   |
| C <sub>4</sub> , C <sub>8</sub> , C <sub>9</sub> & C <sub>11</sub>                    | 20 $\mu$ f, electrolytic, 450 v.                                   | R <sub>17</sub> & R <sub>18</sub> | 47,000 ohms, 1 watt (matched).  |
| C <sub>5</sub>  | 0.005 $\mu$ f, mica, 600 v.  | R <sub>19</sub> & R <sub>21</sub> | 100,000 ohms, 1 watt.   |
| C <sub>6</sub>  | 40 $\mu$ f, electrolytic, 25 v.                                    | R <sub>20</sub>                   | Potentiometer, 100 ohms, 2 watts.   |
| C <sub>14</sub> & C <sub>15</sub>   | 16 $\mu$ f, electrolytic, 600 v.                                   | R <sub>22</sub> & R <sub>23</sub> | 100 ohms, 10 watts.   |
| C <sub>16</sub>   | 0.01 $\mu$ f, mica, 600 v.   | R <sub>24</sub> & R <sub>25</sub> | 1,000 ohms, 1 watt.   |
| J <sub>1</sub>  | Microphone-cable connector.  | R <sub>26</sub>                   | 330 ohms, 10 watts.   |
| J <sub>2</sub> & J <sub>3</sub>   | Normally closed jack.  | R <sub>27</sub> & R <sub>28</sub> | 100 ohms, 2 watts.  |
| L <sub>1</sub> & L <sub>2</sub>   | Filter choke, 8 henrys at 150 ma, Thordarson T20C54 or equivalent. | R <sub>29</sub>                   | Adjustable, 100 ohms, 25 watts.   |
| M <sub>1</sub>  | Meter, 0-500 ma, Weston 301 or equivalent.                         | SW <sub>1</sub>                   | DPST toggle switch.   |
| PL <sub>1</sub>   | Pilot lamp, 125 v., 3 watts.                                       | SW <sub>2</sub>                   | Double-pole triple-throw switch.  |
| R <sub>1</sub>  | 100,000 ohms, 1/2 watt.  | T <sub>1</sub>                    | Driver transformer, primary to 1/2 secondary (5:1), Thordarson 20D82 or equivalent.                   |
| R <sub>2</sub>  | 240,000 ohms, 1/2 watt.  | T <sub>2</sub>                    | Multi-match modulation transformer, Thordarson 21M64 or equivalent.                                   |
| R <sub>3</sub>  | 2,000 ohms, 1 watt.  | T <sub>3</sub>                    | Power transformer, 400-0-400 v, 200 ma; 5 v, 3 amp; 6.3 v, 5 amp, Thordarson TS24R07-U or equivalent. |
| R <sub>4</sub>  | 1.5 megohms, 1 watt.   | T <sub>4</sub>                    | Filament Transformer, 6.3 v at 10 amp, Thordarson T21F12 or equivalent.                               |
| R <sub>5</sub> , R <sub>14</sub> , & R <sub>15</sub>                                  | 470,000 ohms, 1 watt.  |                                   |   |
| R <sub>6</sub> , & R <sub>11</sub>  | 47,000 ohms, 1 watt.   |                                   |   |
| R <sub>7</sub>  | Potentiometer, 0.5 megohm, 1 watt.                                 |                                   |   |
| R <sub>8</sub>  | 470 ohms, 1 watt.  |                                   |   |
| R <sub>9</sub>  | 30,000 ohms, 1 watt.   |                                   |   |

### TVI BIBLIOGRAPHY

A comprehensive listing of articles on TVI and related topics that have appeared since 1946. Although the articles appearing in the non-amateur publications contain only minor references to the amateur and TVI, they have been included to supply the advanced amateur with a complete set of references. A few articles on interference from sources other than amateur transmitters as well as some editorials have been listed. Radio amateur groups will find the editorial articles valuable references for discussions. Note that the articles are listed in chronological order; this has been done to facilitate retrospection, and to permit easy cross reference to TV reception techniques and improvements.

#### 1946

- "Analysis of Parasitic Oscillations in Radio Transmitters," by J. S. Jackson, W9DZR, *Radio News*, Feb. 1946, pg 68.
- "Local Oscillator Radiation and Its Effect on Television Picture Contrast," by E. W. Herold, *RCA Review*, March 1946, pg 32.
- "Radiation from R-F Heating Generators," by A. G. Swan, *Electronics*, May 1946, pg 162.
- "Keeping Your Harmonics at Home," by G. Grammer, W1DF, *QST*, Nov. 1946, pg 13.

#### 1947

- "Television Interference," *CQ*, May 1947, pg 13.

- "Spurious Transmitter Radiations," by E. H. Conklin, W3VQ, *QST*, May 1947, pg 66.
- "Curing Interference to Television Reception," by M. Seybold, W2RYI, *QST*, Aug. 1947, pg 19.
- "Television Interference," *QST*, Aug. 1947, pg 33.
- "Interference with Television Broadcasting," by G. Grammer, W1DF, *QST*, Sept. 1947, pg 24.
- "Engineering Problems Involved in TV Interference," by A. Francis, *Tele-Tech*, Sept. 1947, pg 42.
- "TVI" (editorial), *QST*, Nov. 1947, pg 11.
- "Threshold Diplomacy and TVI" (editorial), *CQ*, Nov. 1947, pg 13.

(Continued on next page)

TVI BIBLIOGRAPHY (Continued)

1948

"Eliminating Spurious Radiations from BC Transmitters," by Dr. V. J. Andrew, *Tele-Tech*, Feb. 1948, pg 22.  
 "Down With Harmonics," by J. H. Owens, *W2FTW*, *CQ*, Feb. 1948, pg 29.  
 "Interference Traps for Television," by S. N. Finley, *Radio News*, March 1948, pg 70.  
 "Growing Threat of TVI" (editorial), *CQ*, March 1948, pg 13.  
 "TVI Can Be Reduced," by P. S. Rand, *W1DBM*, *QST*, May 1948, pg 31.  
 "Cause and Cure of Spurious TV Receiver Oscillations," by R. T. Cavanaugh, *Tele-Tech*, May 1948, pg 36.  
 "TVI" (editorial), *QST*, May 1948, pg 11.  
 "TVI Diplomacy" (editorial), *CQ*, June 1948, pg 13.  
 "You Can Live With TVI," by H. M. Bach, Jr., *W2GWE*, *CQ*, June 1948, pg 33; July 1948, pg 36.  
 "The TV Receiver," by W. Brown, *W2IBK*, *CQ*, July 1948, pg 31.  
 "Television Receiver Intermediate Frequencies," by P. F. G. Holst, *Electronics*, Aug. 1948, pg 90.  
 "TVI Corrective Measures," by W. M. Scherer, *W2AEF*, *CQ*, Aug. 1948, pg 34.  
 "Trap Circuits for Television Receivers," *Radio & Television News*, Sept. 1948, pg 58.  
 "Video Interference," *Electronics*, Sept. 1948, pg 142.  
 "TVI Progress Report" (editorial), *CQ*, Sept. 1948, pg 13.  
 "TV Circuits Cause Interference," *Tele-Tech*, Sept. 1948, pg 39.  
 "TV Interference . . . Causes and Remedies," by I. Kamen, *Service*, Oct. 1948, pg 20.  
 "Traps for TVI Elimination," by F. C. Hills, *QST*, Oct. 1948, pg 132.  
 "TVI," *QST*, Oct. 1948, pg 21.  
 "New Practical Method Developed for Curing TVI," by J. L. Reinartz, *W3RB*, *RCA HAM TIPS*, Nov.-Dec. 1948, pg 1.  
 "TVI from 21 Mc," by G. Grammer, *W1DF*, *QST*, Dec. 1948, Pg 20.

"Harmonic Reduction With Stubs," by R. T. Wilson, *W3JHW*, *QST*, Dec. 1948, pg 58.  
 "More on TVI Elimination," by P. S. Rand, *W1DBM*, *QST*, Dec. 1948, pg 29.

1949

"*TVI Handbook*"—2nd edition, 1949 (Radio Magazines, Inc., N.Y., N.Y.)  
 "Applications of the Grid-Dip Oscillator," by W. M. Scherer, *W2AEF*, *CQ*, June 1949, pg 30.  
 "How Not to Lick TVI" (editorial), *CQ*, Jan. 1949, pg 11.  
 "A Practical Method for Reducing Harmonic Radiation," by J. L. Reinartz, *W3RB*, *RCA HAM TIPS*, Jan.-Feb. 1949, pg 1.  
 "Harmonic Suppression in Class-C Amplifiers," by F. Q. Gemmill, *W2VLQ*, *QST*, Feb. 1949, pg 28.  
 "Another TVI Kink," by R. F. Tesco, *W2TVL*, *QST*, Feb. 1949, pg 60.  
 "The Little Slugger," by P. S. Rand, *W1DBM*, *QST*, Feb. 1949, pg 11.  
 "The Improved Dipper," by W. M. Scherer, *W2AEF*, *CQ*, Feb. 1949, pg 14.  
 "The Trap Box," by W. M. Scherer, *CQ*, March 1949, pg 42.  
 "TVI, Cooperate, But Operate!" (editorial), *CQ*, March 1949, pg 11.  
 National Co. editorial, *QST*, April 1949, pg 61.  
 "The Harmonic Chaser," by W. M. Scherer, *W2AEF*, *CQ*, April 1949, pg 22.  
 "Re 'Harmonic Suppression in Class-C Amplifiers,'" *QST*, April 1949, pg 34.  
 "Pointers in Harmonic Reduction," by G. Grammer, *W1DF*, *QST*, April 1949, pg 14.  
 "High-Pass Filters for TVI Reduction," by G. Grammer, *W1DF*, *QST*, May 1949, pg 46.

This bibliography will be continued in the next issue of *HAM TIPS*.

Devices and arrangements shown or described herein may use patents of RCA or others. Information contained herein is furnished without responsibility by RCA for its use and without prejudice to RCA's patent rights.



From your local RCA distributor, headquarters for RCA receiving and power tubes.

**RCA HAM TIPS** is published by the RCA Tube Dept., Harrison, N. J. It is available free of charge from RCA Distributors

Lawrence LeKashman,  
Editor **W2IOP**

Joseph Pastor, Jr.,  
Assoc. Editor **W2KCN**

If undeliverable for any reason, notify sender, stating reason, on Form 3547, postage for which is guaranteed.

WHEN MAILING  
PLACE POSTAGE HERE

