

HAM TIPS

from



Published by RCA Manufacturing Company, Inc., Camden, N. J., U. S. A.

VOL. 3—No. 2

CAMDEN, N. J.

MARCH—APRIL, 1940

NEW BOTTLES PUT OUT REAL POWER ON U. H. F.'s

AR-77 FEATURES HIGH SIGNAL-TO-NOISE RATIO

Builds Up Weak Sigs Ordinarily Lost in Receiver Background Noise

By Edward Braddock

Manager of RCA Amateur Equipment Sales

One of the most important yardsticks for measuring the performance of a receiver is its Signal-to-Noise Ratio. This measurement indicates the degree of receiver sensitivity and is defined as the ratio between the developed signal voltage and the developed circuit noise voltage. The higher this ratio is, the better is the signal intelligibility.

Modern tube developments have advanced circuit sensitivity to such a high degree that certain objectionable physical phenomena occurring in the tube circuit and in the tube itself actually become audible when receiver gain is advanced. In other words, inherent tube sensitivity has advanced the threshold of weak signals so much that it has brought to light other circuit limitations. These objectionable physical phenomena show up in receiver output as a steady hissing noise which can be loud enough to cover up an otherwise readable signal. The common expression "down in the mud" well

MEGACYCLES?—GOING UP!

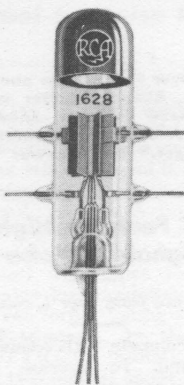

The new RCA-1628 transmitting triode takes maximum ratings as high as 500 Mc and reduced ratings up to 675 Mc.

describes a weak unintelligible signal mixed up in such a background.

AR-77 Has High Sig./Noise Ratio

In the design of the new AR-77 Communication Receiver, RCA engineers recognized from the start the vital importance of designing a superior receiver with an improved signal-to-noise ratio, particularly for the amateur bands where some of the choicest DX contacts require reception of extremely weak signals—signals that

(Continued on page 2, column 3)

LATEST XMTG TUBES MEET DEMAND FOR TYPES IN THE H-F SPECTRUM

RCA-829 Needs No Neutralizing to 250 Mc; RCA-1628 Takes Max. Ratings to 500 Mc!

FISTFUL OF POWER

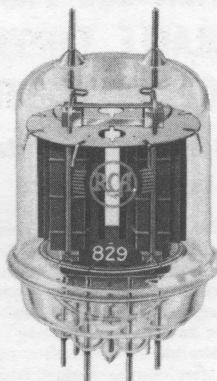

New P-P Beam Power RCA-829 takes 120 watts at the handy plate voltage of 500 volts. Goes all the way to 1½ meters. Only 4½" high and 2½" in diameter.

Filled is that long need by experimenters for transmitting tubes that will "deliver the goods" at the ultra-high frequencies. The newly announced Push-Pull Beam Power Amplifier RCA-829 and the double-lead H-F Triode RCA-1628 are capable of kicking out plenty of power at the ultra-highs with good efficiency and low driving power. In properly designed circuits, these tubes perform as smoothly at a few meters as they do at several hundred.

829 Two Tubes in One

The RCA-829 contains two beam power units within one bulb. The cathodes are connected together within the tube. The heaters are connected in series. The center heater connection is brought out of the bulb to a separate terminal to permit either series operation from a 12.6-volt supply or parallel operation from a 6.3-volt supply. Maximum

(Continued on page 2, column 1)

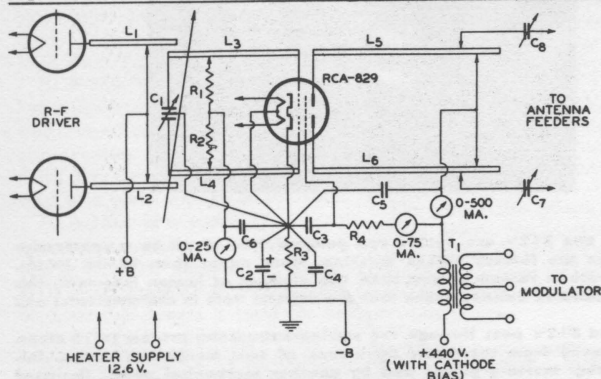

RCA-829 200-Mc R-F POWER AMPLIFIER

- $R_1 R_2 = 7500$ to 15000 ohms, 1 watt.
- $R_3 = 60$ ohms, 10 watts.
- $R_4 = 6400$ ohms, 15 watts.
- $T_1 =$ Modulation Transformer.
- $C_1 = 1.2$ to $10 \mu\text{f}$ per section.
- $C_2 = 25 \mu\text{f}$, 200 volts.
- $C_3 C_4 C_5 C_6 = 500 \mu\text{f}$, Mica.
- $C_7 C_8 = 3$ to $35 \mu\text{f}$.

PRICES GREATLY REDUCED

We are pleased to announce substantial price reductions on three important transmitting tubes, as follows:

Type	Previous Net Price	New Net Price
813	\$28.50	\$22.00
832	28.75	17.00
1624	4.75	3.50

As you know, the 813 is a high power beam type capable of taking 360 watts input up to 30 Mc. At the new net price of \$22.00, this tube now gives more than 16 watts/dollar—in addition to its inherent features of making it practical to reduce the number of driver stages and to eliminate neutralizing worries. Only ½-watt of r-f drive is required at 2,000 volts. When used as a crystal

(Continued on page 3, column 1)

READY FOR YOU

Too big to squeeze into this issue of Ham Tips and too good to split into serials, that hot constructional story on the 225-watt 811 class B modulator and its associated 750-watt high-voltage power supply we've been promising is now available in a separate and complete bulletin. Data includes photographs, layouts, a-f power output curves, harmonic distortion curves, and frequency-response curves, as well as circuits for a complete speech amplifier and class AB₁ driver. The design of the 1250/1500 volt, 500-ma. power supply also is included. This supply is capable of operating both the 811 modulator and a p-p 812 r-f amplifier (described in November Ham Tips).

Write to the RCA Manufacturing Company, Inc., Commercial Engineering Section, Harrison, New Jersey, for your free copy.

HAM TIPS from RCA

New Bottles Put Out Real Power on U. H. F.

(Continued from page 1, column 4)

CCS ratings of the tube in class C telegraph service are: D-c plate voltage, 500 volts; total maximum d-c plate current, 240 milliamperes; and total maximum plate dissipation for both units, 40 watts. *Maximum plate input is 120 watts!* Typical power output is approximately 83 watts.

The exceptional efficiency and high power sensitivity of the tube permit full power output with very low driving power. For example, a single 829 operated in push-pull class C telegraph service is capable of handling its rated power input of 120 watts with less than a watt of r-f grid drive—at frequencies as high as 200 Mc (1½ meters). The tube may be operated with reduced ratings at frequencies as high as 250 Mc. Outstanding among the features of the 829 is the fact that it can be operated at these extremely high frequencies without neutralization, provided, of course, that the circuits are adequately shielded.

Symmetry is Keynote

The unusually fine performance of the 829 at the ultra-high frequencies is made possible by the balanced and compact structure of the beam power units, excellent internal shielding, and close electrode spacing. Furthermore, the internal leads are short and heavy to minimize internal lead inductance. The terminals are arranged to provide excellent insulation and to facilitate symmetry of circuit layout.

A 200-Mc. circuit employing the 829 is shown on page 1. Plate-circuit tuning is accomplished by adjustment of the shorting bar along the plate lines L₅L₆. These lines are made of 3/8" diameter copper tubing, approximately 7" long and spaced approximately 7/8" between centers. Grid-circuit tuning is accomplished by C₁ which shunt tunes the grid lines. L₃L₄ are each made of 1/4" copper tubing, approximately 10" long and spaced approximately 7/8" between centers. They are 1/2-wave long each. The grid resistors should be adjusted on L₃L₄ at the voltage node. Dimensions of the driver plate lines are dependent on the type of driver tube used. Ordinarily they are approximately the same as L₅ and L₆.

1628 is H-F Specialist

The new RCA-1628 triode is a general-purpose transmitting tube for use as an oscillator, r-f power amplifier, and frequency multiplier at the ultra-high frequencies. It is capable of running at maximum ratings at frequencies as high as 500 Mc and at reduced ratings as high as 675 Mc! Outstanding among the features of this triode is its double-helical, thoriated-tungsten filament which is center-tapped within the tube. The center tap is brought out of the bulb to a separate lead. By connecting all three filament leads in parallel

(Continued on page 3, column 1)

ETHER BUSTER USES RCA-806

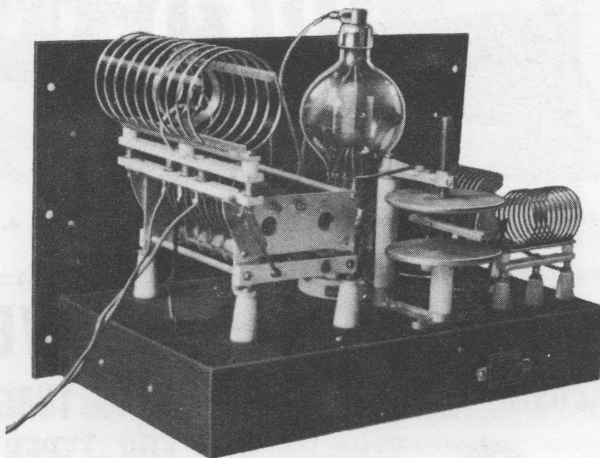

W2HNP of Roselle Park, New Jersey, rates a five for this fine photo. Tube line-up consists of an RCA-6L6 crystal oscillator, RCA-809 buffer amplifier, and an RCA-806 final with the famous Enclosed Tantalum Anode. Says W2HNP, "the 806 is working swell on all bands—operates on both phone and c.w. with between 400 to 600 watts input." More power to you, Om—if you need it!!

STATION LOG PADS AVAILABLE THROUGH YOUR DISTRIBUTOR

Well layed-out Sheets Make
Logging a Pleasure

The RCA Log Sheets, now carried by your power tube distributor, are going a long way toward taking the drudgery out of station operation "bookkeeping." Designed by amateurs for amateurs, these 8½" x 11" sheets are laid out in such a manner that entries can be logged from left to right—in just the order that QSO procedure takes place. The top of each sheet provides itemized space for the required entry of your station call, address, name, and the sheet number. The QSO items from left to right are: Station, Worked or Called, Time (begun/ended), RST (his/mine), Frequency or Dial Degrees (his/mine), Final Stage Input Watts, and a 3 5/8"-space for the Date, Type of Emission, QTH, Remarks, etc., items. There is plenty of room on the sheet to write without cramping.

An unusual feature of the log pages is their right-hand perforations for fitting into three-ring binders. When the binder is opened, this places the sheet in use on the left side of the binder, while the blank side of the next sheet falls on the right side of the binder. Thus, each sheet serves a double purpose by providing a handy note page for jotting down the usual informal QSO comments, drawing sketches, and "doodling."

RCA Log Sheets come in pads of 25 each. One pad provides space for 725 entries. See your transmitting tube distributor for your supply.

AR-77 Features High Signal-To-Noise Ratio

(Continued from page 1, column 2)

have to compete with receiver noise background. To increase receiver sensitivity without keeping set noise to a minimum would not give better reception. But, to increase the ratio between developed signal voltage and noise voltage does count

—and plenty, too. The higher this ratio is made the better is signal intelligibility.

Let us take a look at the physics of noise developed in receiver circuits and see how RCA engineers handled the problem in the AR-77.

R-F Circuits Have High L/C Ratio

The primary source of circuit noise ("built-in" noise) is caused by thermal agitation, or state of molecular unrest, in the resonant circuits of the r-f preselector stage. The same phenomena also exists in the antenna but here its effects are negligible. Thermal agitation voltage in the first tuned circuit increases as the square root of the impedance. The signal voltage developed across an impedance varies directly as the impedance. By increasing the input-resonant impedance, it is possible to raise the signal-to-noise ratio. Low-loss circuits having high inductance-to-capacity ratios raise the resonant circuit impedance. The AR-77 takes this requirement into account by using specially designed low-loss tuning inductances having POLYSTYRENE insulation and magnetite cores.

Another design problem confronting the receiver engineer is the LC ratio of the tuned circuits. This ratio is determined by the tuning range of the receiver and by the practical necessity of meeting customer requirements for high performance with general frequency coverage.

With these factors in mind, the logical choice is to design the circuits to have as high an LC ratio as is practical for each frequency range

(Continued on page 3, column 2)

30 EVERY 60 MINUTES

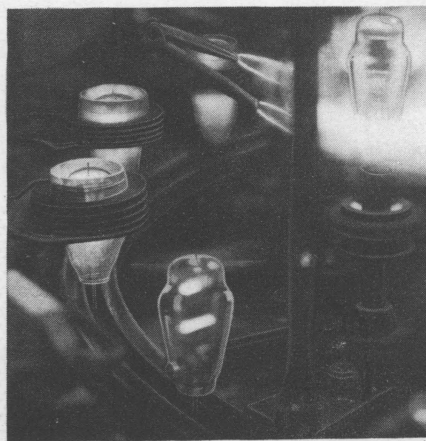

RCA-811's and 812's are sealed and pumped free of air in a spectacular run through the famous SEALEX machine. More adept than human hands, more accurate in vacuum control than the element of human judgment, this machine produces finished tubes that are uniform both in characteristics and in quality.

811's and 812's pass through the sealing-exhausting process in 16 steps. Air is removed from the tubes by means of two mechanical pumps, followed by four mercury pumps and by another mechanical pump. Occluded gas from the glass parts of the tube is removed by flames which blast the bulbs to near melting point. Occluded gas from the metal parts is removed by heating them to incandescence in terrific r-f fields. Finally, the tube "getter" is flashed to absorb, in conjunction with the famous Zirconium-Coated Anode, any last trace of gas.

New Bottles Put Out Real Power On U.H.F.

(Continued from page 2, column 1)

through r-f by-pass condensers, it is practical to minimize the effect of filament-lead inductance. Important also are the double grid and plate leads which are brought out of the bulb through individual seals. In amplifier service, the double leads facilitate neutralization by eliminating common impedances between tank and neutralizing circuits within the tube. In oscillator service, it is desirable to connect these leads in parallel to reduce their respective inductances. RCA-1628 utilizes a closely spaced grid and plate construction. This design decreases electron transit-time between the filament and plate and thereby improves the efficiency of the tube at the ultra-high frequencies. The grid and plate are made of tantalum.

Maximum CCS ratings of the 1628 in class C telegraph service are: D-c plate voltage, 1000 volts; d-c plate current, 60 ma.; plate input, 50 watts; and plate dissipation, 40 watts. Typical driving power at a plate voltage of 1000 volts is approximately 1.7 watts; typical power output, approximately 35 watts. Filament rating of the tube is 3.5 volts at 3.25 amperes.

The RCA-829 and RCA-1628 are now available to experimenters and amateurs through RCA Tube Distributors. Net price of the 829 is \$19.50; net price of the 1628 is \$32.00. For additional technical information on these two ultra-modern transmitting tubes, write to the Commercial Engineering Section, RCA Radiotron Division, Harrison, New Jersey.

Prices Greatly Reduced

(Continued from page 1, column 3)

oscillator, RCA-813 makes an efficient one-tube transmitter of relatively high power (see December, 1938 Ham Tips).

RCA-832 is the tiny push-pull beam power tube that takes up to 36 watts input at 2 meters. This tube also requires no neutralization. R-f drive for the 832 is less than 0.2 watt at a plate voltage of 400 volts.

RCA-1624 is a metal type beam power transmitting tube capable of taking 54 watts input up to 60 Mc. It is designed with a fast-heating filament that makes it ideal for use as an a-f or r-f amplifier, modulator, frequency multiplier, or oscillator in equipment where quick off-on operation is essential.

Take advantage of the new prices on these types to build that unusual rig you have been planning.

TWO RCA-804's FEATURE FLEXIBILITY, VERSATILITY

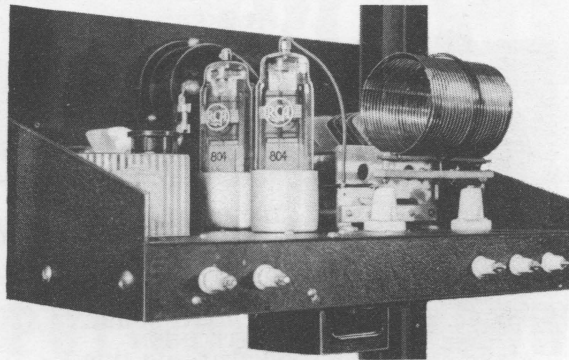

AR-77 Features High Signal-to-Noise Ratio

(Continued from page 2, column 4)

and to be sure that each amateur band is completely covered with adequate overlap between ranges. The harmonic relationship of the amateur bands, along with the included broadcast band, requires a total of six tuning ranges—and the AR-77 has this number of ranges. It is also of paramount importance to use extremely low-loss insulating material for the coil forms, tuning condenser, and r-f trimmers. In the AR-77, POLYSTYRENE insulation is used for the two highest range coils and high grade bakelite for the lower frequency ranges. Ceramic insulation is used in the tuning condensers,

DID YOU KNOW THAT—

- the air pressure within an average radio tube envelope is only one one hundred millionth that of atmospheric pressure at sea level?
- some receiving tubes contain as many parts as a fine 17-jeweled watch?

trimmers, and r-f tube sockets as well as in the range switch. Furthermore, it is essential to consider the problem of signal transfer from antenna to receiver. The AR-77 antenna coupling coil is arranged to give maximum signal voltage transfer from antenna to the first tuned circuit. The antenna trimmer allows the first r-f circuit to be peak-tuned at all times—thereby maintaining the maximum Signal/Noise ratio on whatever frequency the receiver is tuned.

The cumulative effects of all these careful design considerations in the AR-77 makes its ratio of weak signal voltage to thermal agitation voltage unusually high as compared with previous designs.

AR-77 Minimizes "Shot Effect"

Circuit noise may also be produced by the flow of the electron stream from tube cathode to plate. Extensive studies show that for two small intervals of time, the quantity of

electrons flowing between cathode and plate is not uniform. This irregularity occurs throughout the radio spectrum and means that wherever the receiver is tuned the noise or hiss caused by this effect is present. The phenomenon is known as "shot effect." Factors controlling "shot effect" are plate current and band width. The effect varies as the square root of each of these factors.

The AR-77 minimizes "shot effect" by establishing the plate current of the r-f tubes as low as will maintain their transconductance and give maximum gain.

The band-width factor is controlled by the overall r-f selectivity of the AR-77 itself. It is interesting to note at this point that the first step in the crystal-filter circuit narrows the band width and greatly reduces the noise from "shot effect" without materially affecting the intelligibility of voice-modulated signals and without producing excessive high-frequency, side-band reception.

The net result of including these considerations in the design of the AR-77 makes it a "natural" for pulling in more signals than ever before possible, particularly those weak ones down around a microvolt or less.

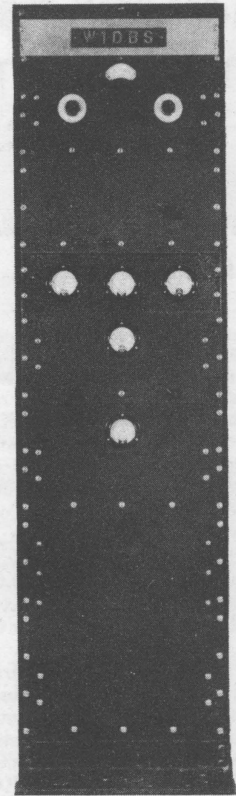

W1DBS of New Britain, Connecticut, well deserves the \$5.00 in the mail for him for these excellent views. His rig uses an RCA-89 crystal oscillator, an RCA-807 buffer amplifier, and a pair of RCA-804's in push-pull in the final. No neutralizing headaches to worry about in this job. The transmitter works five bands (160, 80, 40, 20, 10) and uses both c.w. and phone. On phone, the 804's are plate-modulated with a pair of RCA-801-A/801's in class B. "I use RCA tubes throughout," says W1DBS. We're proud to know that he does.

2 RCA-811's DELIVER 225 WATTS OF A. F.

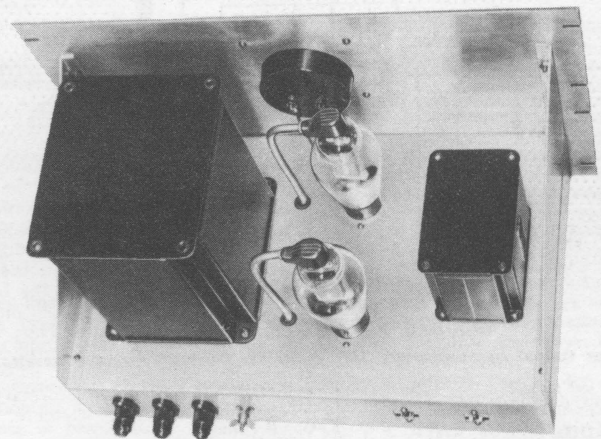

This photograph is but a sample of what you receive when you ask for the Special Ham Bulletin covering the design of the 811 class B modulator and its associated power supply. Be sure to write for your free copy.

HAM TIPS from RCA

RCA-828 BEAM TUBE TAKES 270 WATTS (ICAS) ON C.W.

**Max. Plate Input Is 200 Watts
for Plate Modulation**

The multi-electrode transmitting beam power tube RCA-828, which was recently announced to radio amateurs, is the logical answer for those who desire the utmost in efficiency for medium-powered rigs. In r-f services it will give full output with very low driving power. Consequently, fewer driver stages are required. Almost any small tube will serve as a driver. A Tritet 6L6 or 6V6-G oscillator will excite the 828 even when frequency doubling is used in the oscillator plate circuit.

The 828 is ideal for use in transmitters where quick band change without neutralizing adjustments is desired. It will take maximum ratings at frequencies as high as 30 Mc and reduced ratings up to 75 Mc. RCA-828 is also well-suited for use as a frequency multiplier, oscillator, class AB₁ modulator, and grid- or plate-modulated r-f power amplifier. The tube is equipped with the new "MICANOL" base. A circuit showing application of the 828 in c-w service is shown below. Data for class C telegraphy are listed on this page. Amateur net price of the 828 is \$17.50. For additional information on this tube, write to the Commercial Engineering Section, RCA Manufacturing Company, Harrison, N. J.

EASY TO DRIVE

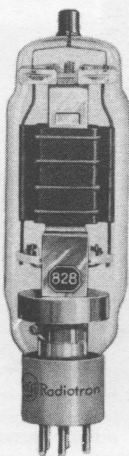

High power sensitivity and a power output of 200 watts make the RCA-828 one of the most popular Beam Power tubes ever introduced for medium-power transmitters.

HAMS PLEASE NOTE! WIN \$5.00!

**Does Your Transmitter Use
RCA Tubes Throughout?**

If so, send us a photograph and a brief description of it. Photos of final amplifier stages are also suitable. We should like to publish one or more such photos in each issue of HAM TIPS. Those published win \$5.00 cash. "Commercial type" rigs are not given preference—what have you?

(This offer good in Western Hemisphere, Hawaii, and the Philippine Islands.)

RCA-828

TENTATIVE RATINGS

FILAMENT VOLTAGE (A.C. or D.C.)	10.0	Volts
FILAMENT CURRENT	3.25	Amperes
DIRECT INTERELECTRODE CAPACITANCES:		
Grid-Plate (with external shield)	0.05 max.	μf
Input	13.5	μf
Output	14.5	μf

As R-F Power Amplifier and Oscillator—Class C Telegraphy

Key-down conditions per tube without modulation

	(CCS)	(ICAS)	
D-C PLATE VOLTAGE	1250 max.	1500 max.	Volts
D-C SUPPRESSOR VOLTAGE	100 max.	100 max.	Volts
D-C SCREEN VOLTAGE	400 max.	400 max.	Volts
D-C GRID VOLTAGE	-300 max.	-300 max.	Volts
D-C PLATE CURRENT	160 max.	180 max.	Ma.
D-C GRID CURRENT	15 max.	15 max.	Ma.
PLATE INPUT	200 max.	270 max.	Watts
SUPPRESSOR INPUT	5 max.	5 max.	Watts
SCREEN INPUT	16 max.	16 max.	Watts
PLATE DISSIPATION	70 max.	80 max.	Watts

TYPICAL OPERATION:

D-C Plate Voltage	1250	1500	Volts
D-C Suppressor Voltage	75	75	Volts
D-C Screen Voltage	400	400	Volts
D-C Grid Voltage:			
From a fixed supply of	-95	-100	Volts
From a grid resistor of	7900	8300	Ohms
or from a cathode resistor of	415	430	Ohms
Peak R-F Grid Voltage	195	205	Volts
D-C Plate Current	160	180	Ma.
D-C Suppressor Current	22	14	Ma.
D-C Screen Current	35	28	Ma.
D-C Grid Current (Approx.)	12	12	Ma.
Driving Power (Approx.)	2.1	2.2	Watts
Power Output (Approx.)	150	200	Watts

POWER ON 1½ METERS

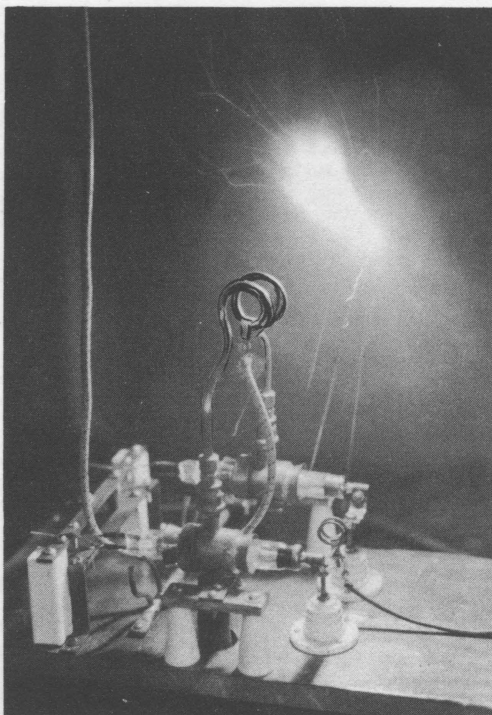

This is a high-frequency test oscillator in action. It uses two RCA-887's—small, water-cooled triodes built particularly for use at the ultra-high frequencies and which measure only 7½" high. The oscillator in this picture is capable of producing 1100 watts of useful power in the output circuit—at 100 Mc! Photograph shows a part of the output energy being dissipated in a standing arc. The discharge is so intense that small particles of molten metal are being expelled from the contact wire. Paths of these particles are indicated by streaks surrounding the discharge.

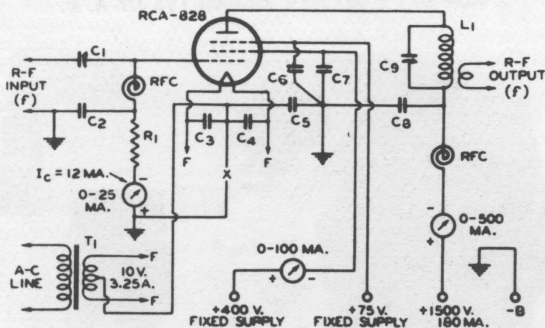

RCA-828 R-F POWER AMPLIFIER

Power Output Approximately 200 Watts for Class C Telegraphy Service

- C₁ = 50 μf midget.
- C₂ C₃ C₄ = 0.005 μf, mica.
- C₅ C₈ = 0.002 μf, mica, 5000 v.
- C₆ C₇ = 0.01 μf, mica.
- C₉ = 1.5 μf/meter*.
- R₁ = 8300 ohms, 4 watts.
- L₁ = Tune to frequency "f".
- RFC = R-f choke.
- T₁ = Filament transformer, 2000-v. insulation.
- f = Operating frequency.
- x = Insert keying relay here.

* Capacitance in actual use. Minimum air-gap should be 0.07".

NOTE: Power output of driver stage should be about 5 watts.

The license extended to the purchaser of tubes appears in the License Notice accompanying them. Information contained herein is furnished without assuming any obligation.