



## OSCILLATOR-MONITOR

Phone—CW Monitor and Code Practice Oscillator  
for Novice or Oldtimer

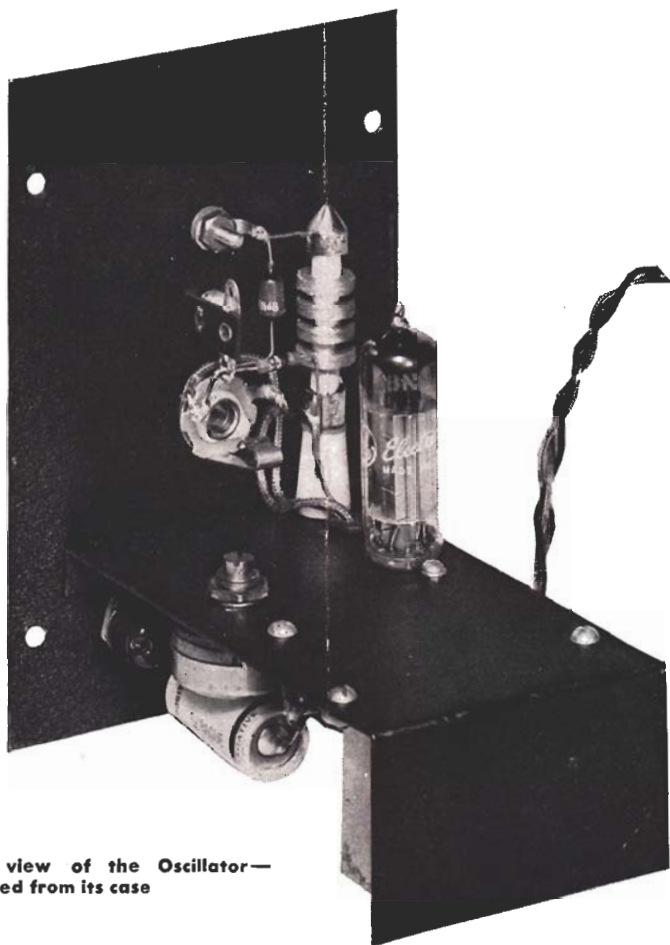

Fig. 1. Rear view of the Oscillator—Monitor removed from its case

### Contents

Oscillator—Monitor.....	pages 1-4
Tricks & Topics.....	page 5
Designer's Corner.....	page 6
Sweeping the Spectrum.....	page 7
Technical Information (1N48).....	page 8

# OSCILLATOR-MONITOR

This monitor enables the c.w. operator to hear his own keying, and it allows the 'phone operator to constantly listen to his modulated signal. Also, this device can serve as an audio oscillator, which may be used for code practice work or for m.c.w. operation. This Oscillator-Monitor would be especially useful to the beginning amateur, as it could be used for code practice work in the beginning, and serve as either a 'phone or c.w. monitor after the station was built and on the air.

## ELECTRICAL DETAILS

With reference to the circuit diagram, Fig. 2, it will be seen that a single 6BN6 tube is employed. This tube is a 7-pin miniature tube of recent design, and is known as a gated-beam tube. While similar in appearance to regular receiving tubes, the 6BN6 is actually a new species of tube, with several interesting characteristics. For example, this tube is capable of cutting off its own plate current with its own self bias.

In the Oscillator-Monitor circuit the 6BN6 is used in this manner. A portion of the tube operates as an audio oscillator. Another section of the tube is triggered by an incoming r.f. signal so as to allow the audio frequency note to pass through the tube to the output circuit. This action provides monitoring action for c.w. operators. For use as a code-practice oscillator, the keying circuit triggers the tube, rather than the r.f. signal, and again the output circuit receives the audio tone. For 'phone work, the oscillator section is put out of action, and the tube acts as an audio amplifier.

Refer again to Fig. 2. When switch S is open, and no r.f. signal is present on grid 3, the following occurs. Grid 2 is supplied with approximately 80 volts through the transformer, T. The resulting current flows through the cathode bias resistor  $R_3$ , and the voltage drop across this resistor is a bias sufficient to stop the plate current flow. The bias on grid 1 is adjusted, by means of  $R_3$ , until grid 1 and grid 2 form a negative transconductance oscillator. The exact frequency is determined by the constants of T,  $C_2$ ,  $C_3$  and  $R_2$ .

Now, even though this section is oscillating, no audio output will appear in the plate circuit because the tube is supplied with cutoff bias. However, we can overcome this bias by connecting the cathode of the tube to grid 3. By placing a key between these two points the audio tone is passed on to the plate circuit and a code oscillator is formed. We can accomplish the same action and again overcome the cutoff bias by means of the r.f. signal. In this case the signal is picked up by the antenna post, is rectified by a germanium diode, and the resulting d.c. bias triggers the tube and passes the audio tone through to the plate circuit. If the r.f. signal picked up is a keyed signal, then the audio tone appearing in the output circuit is a faithful reproduction of the signal being transmitted. Note that this monitor is actuated from the r.f. signal itself, so that if you hear an audio tone, you know that the transmitter is actually on the air.

For 'phone monitoring, switch S is closed, which stops the oscillation between grid 1 and 2. Now, the germanium diode, G, acts as a detector to remove the audio intelligence from a 'phone signal, and the 6BN6 acts as an audio amplifier.

## CONSTRUCTIONAL DETAILS

The unit shown in the photographs contains no power supply. One could be built to use with the Oscillator-Monitor, but the power requirements are so low that most builders will want to supply power from a source already available. The voltage required is 80 to 300 volts, and the current drain is approximately 10 ma. For battery operation, 90 volts is recommended.

Referring to the photographs, the unit is built in a 4 by 5 by 6 inch utility cabinet. The one shown (ICA No. 3819) has a handy shelf attached to the front panel which serves as the chassis. Parts placement is not critical, but the layout shown is a tried and tested mechanical arrangement. As shown in Fig. 3, the antenna post, the keying jack ( $J_1$ ), the output jack ( $J_2$ ) and the switch are placed on the front panel. Jack  $J_1$  is just below the antenna post.

## Electrical Circuit

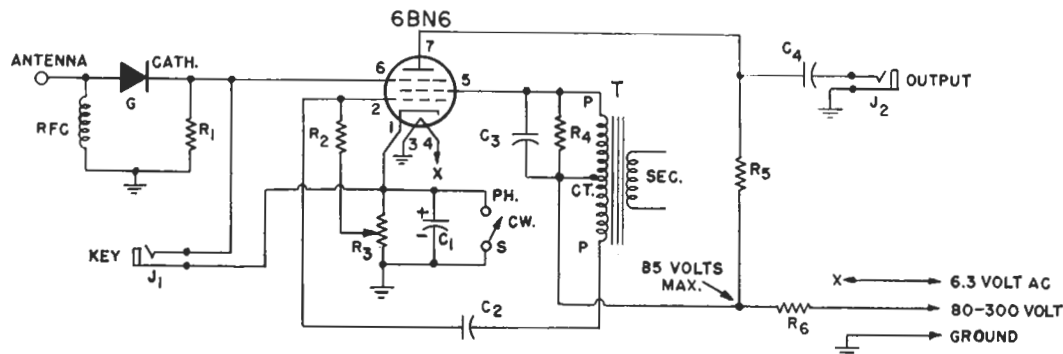

Fig. 2. Circuit diagram of the Oscillator-Monitor

The cathode bias resistor,  $R_3$ , is mounted on the chassis and is provided with a screwdriver slot for adjustment. Once this control is set no further changes are required in the setting unless another tube is used. Fig. 1 shows how the r.f. part of the circuit is mounted above the chassis. All other parts are mounted under the chassis. A hole must be provided in the rear of the cabinet to pass the three-wire power cable.

The antenna post and the keying jack must be insulated from the front panel. This may be accomplished with fiber washers. The output jack does not require insulation, but make certain that condenser  $C_4$  connects to the ungrounded terminal of this jack.

The germanium diode, G, is connected as indicated. Most diodes are marked with a line around one end. This end is the cathode end, and should connect to  $R_1$ , as the circuit diagram indicates.

Transformer T is a standard universal output transformer. The secondary is not used. The primary is connected as indicated, using the push-pull connection, with one plate end going to pin 5, the other plate end going to  $C_3$ , and  $C_3$  and  $R_4$  connected from the center-tap to the plate end which connects to pin 5.

In the circuit diagram you will note that a maximum voltage of 85 volts may exist at the junction of  $R_5$  and  $R_6$ . This is very important. If too much voltage is applied to grid 2, the tube will not operate in the intended manner, and it may be damaged. Resistor  $R_6$  is intended to drop the voltage to approximately 80 volts when 300 volts is applied externally. If you intend to use an external source of voltage which is lower than 300 volts, then  $R_6$  may be made smaller. For example, if you use 100 volts,  $R_6$  could be 1500 ohms. Whatever the external voltage may be, use a value for  $R_6$  which will reduce the voltage on the other side of  $R_6$  to at least 85 volts, and you may go as low as 50 volts at this point if you wish.

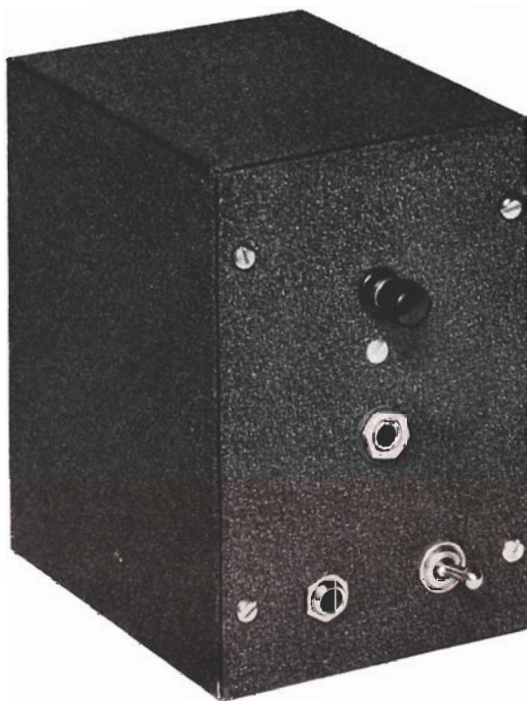

Fig. 3. Front view of the Oscillator-Monitor

#### CIRCUIT CONSTANTS

(All resistors and capacitors = 20% tolerance unless specified otherwise)

$C_1$ .....	10 mf 50 volt electrolytic (Sprague TA 510)
$C_2$ .....	1000 mmf mica or ceramic or paper
$C_3$ .....	6000 mmf mica (see text)
$C_4$ .....	0.05 mf paper
G.....	Crystal diode (G-E 1N48)
$J_1, J_2$ .....	Open-circuit phone jack
$R_1, R_5$ .....	0.1 megohm, $\frac{1}{2}$ watt
$R_2$ .....	0.47 megohm, $\frac{1}{2}$ watt
$R_3$ .....	500 ohm potentiometer
$R_4$ .....	33,000 ohm, $\frac{1}{2}$ watt (see text)
$R_6$ .....	22,000 ohm, 2 watt (see text)
RFC.....	2.5 mh r-f choke (Millen No. 34100)
S.....	SPST toggle switch
T.....	Universal output transformer (Stancor A-3823)

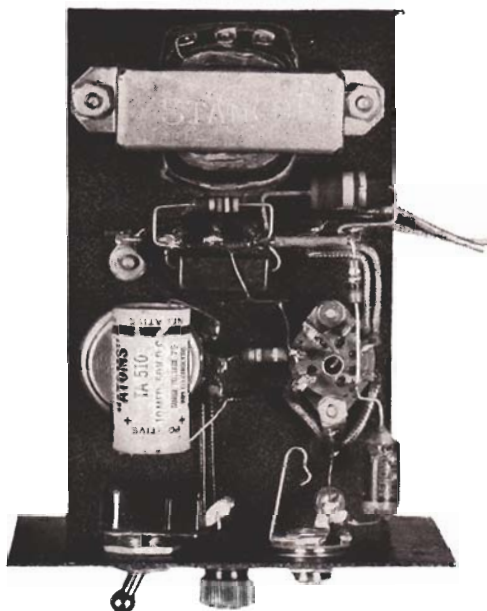

Fig. 4. Under-chassis view of the Oscillator-Monitor

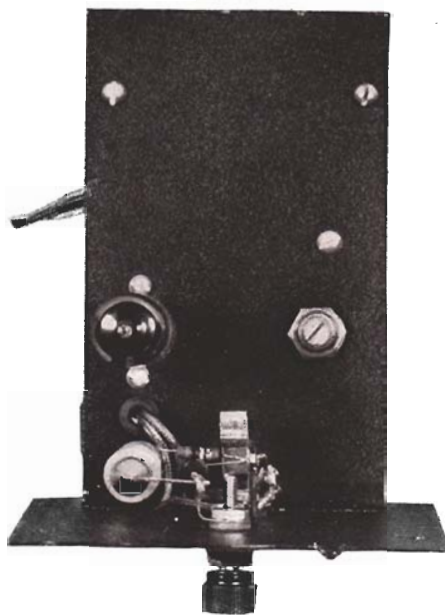

Fig. 5. Top-chassis view of the Oscillator-Monitor

### TUNE-UP ADJUSTMENTS

After the unit is completed, connect 6.3 volts a.c. between ground and the filament connection wire. Next, connect the high voltage with the negative connection to ground and the positive connection to the lead marked 80-300 volts. Make certain that switch S is open (in the c.w. position).

Plug a key in the key jack and close the key. Insert a pair of earphones in the output jack, and listen for an audio note. Adjust  $R_3$  until you get a good, clear note. Try the key to make certain that the note can be keyed.

If the note is the wrong tone, change the value of  $C_3$ . A larger value will give a lower tone, and a smaller value will give a higher tone. The value specified will produce a satisfactory tone with the transformer specified, but if another type of transformer is used, it may be necessary to change the value of  $C_3$  until a pleasing tone is obtained.

If you do not obtain a tone with the key closed, change the value of  $R_4$  to a higher value, say 50,000 ohms. If you obtain a tone regardless of whether the key is closed or not, change  $R_4$  to a lower value, and keep decreasing the value of  $R_4$  until the tone no longer appears when the key is open.

The unit should now be in operating order. To check the operation as a monitor, place an antenna on the antenna post. This may be a piece of wire whose length depends upon the power of the transmitter being monitored. If you are using a low-power transmitter, you may need to run the wire near the antenna feedline in order to get enough energy to trigger the unit. Do not use any more wire for an antenna than is absolutely necessary because it is possible to overload the monitor. When the monitor is overloaded it will not oscillate. When you have the proper amount of pickup, an audio note will appear in the earphones when you key the transmitter.

If the transmitter does not seem to trigger the unit, you may have the germanium diode connected in backwards. Reverse the connections in this case.

In order to make the unit more sensitive to r.f. signals, the r.f. choke may be replaced with a tuned circuit. Generally this will not be necessary, and the circuit as shown should work on almost any amateur band.

For 'phone monitoring you may test the unit by modulating your transmitter, and checking to see if the voice is heard. Switch S must be closed for 'phone monitoring. If you live close to a local broadcasting station you may find that you will hear this station. This is to be expected, because the monitor is working as a monitor for the local broadcast station. If the station is loud enough to be troublesome, you may have to put a wavetrap in the antenna circuit.

### USING THE OSCILLATOR-MONITOR

When used as a 'phone monitor, earphones must be employed. However, when the unit is used as a keying monitor the earphones may be replaced with a small speaker and matching transformer. A universal output transformer with its primary connected to the output jack will serve nicely. It is also possible to feed the output of the monitor directly into the audio input of the receiver in use, and thus take advantage of the audio amplifier and speaker in the receiver. In this way the received signal will be heard on the receiver when you are in contact with some amateur, and your own signal will be fed into the receiver through the monitor when you are transmitting. No switching is required, although some means must be used to make the receiver insensitive to your own transmitted signal.

How did you solve that last problem that almost had you stumped? Be it about tubes, antennas, circuits, etc., Lighthouse Larry would like to tell the rest of the hams about it. Send it in! For each "trick" published you win \$10 worth of G-E Electronic Tubes. Mark your letter "Entry for Tricks and Topics" and send to Lighthouse Larry Tube Division, Bldg. 269, General Electric Company, Schenectady, New York, or in Canada to Canadian General Electric Company, Ltd., Toronto, Ontario. The Companies shall have the right, without obligation beyond the above, to publish and use any material submitted to this column. No entries returned.

### OLD TUBES AS BLEEDERS

Out-of-date transmitting triodes, or extra surplus-purchased triodes can be made to serve quite easily as high wattage bleeder resistors. A tube with a plate dissipation of fifty watts can be used as a fifty-watt bleeder resistor, for example.

Such tubes may be used as follows. Connect the filament center-tap to a self-bias resistor and thence to B minus. Connect the anode to B plus, and the grid to B minus. Use a spare filament transformer to supply the normal filament voltage.

The value of the resistor should be such as to permit the desired bleeder current to be drawn when the power supply is operating. This current times the power-supply voltage should not exceed the dissipation rating of the tube.

For example, a GL-203-A tube has a plate dissipation of 100 watts (the maximum CCS dissipation rating). If used as a bleeder on a 1000-volt power supply, a 50-ohm, 2-watt resistor will provide a bias of approximately minus 5 volts, and a current of 100 mils will flow. This is the maximum current which may be drawn and still keep the tube within the dissipation rating at 1000 volts. A larger value of resistance may be used if a lower current is desirable.

When the tube characteristics are unknown, the value of the bias resistor may be determined experimentally. Be sure to provide a resistor of sufficient power rating so that the bleeder current squared times the resistance is well within the resistor wattage rating.—W2KUJ

### HOMEMADE TOOL FOR TWINLEAD

A very handy cutting and stripping tool for twinlead can be made from a pair of old scissors. Refer to Fig. 6. Procure a pair of old household scissors, or an inexpensive pair of children's scissors. About one inch from the pivot point file or grind a V in each blade, so that when the blades are closed a little bit of light can be seen through the blades. Next, enlarge this area with a file or drill until you have a hole which is slightly larger than the diameter of the twinlead wire. Now, file or grind a slight angle on the sides of the V's to form a good cutting edge. Finally, grind off the end of the scissors so that there is about one-half inch of blade from the center of the V's to the end of the blades.

The portion of the scissors from the V back to the pivot is normally used to cut the twinlead, and the front portion is used, with the V itself, to cut the internal portion of the insulation and to strip the

wire. The hole at the middle of the V portion straddles the wire and acts as the stripper.—W8TIC

### MICROPHONE JACK SHIELD

Here is a simple and economical way to completely shield the microphone input jack on speech amplifiers. Procure one of the small aluminum screw-top cans in which each 35 mm. camera-film cartridge comes packed. Place the cap on a flat surface and with a small hammer, from the inside, pound out the small dome so that the top is flat. Then, drill a hole in the center of the cap and mount it directly on the rear of the microphone connector. If desired, a small hole can be punched with an icepick in the side of the cap near the top to permit the exit of a ground lead. If this is done, be sure the hole is above the threads.

Finally, cut a hole in the center of the bottom of the can, insert a rubber grommet, and you are finished. Plenty of room is provided inside the can for the grid resistor, and the bottom is easily unscrewed when access is desired.

The best way to make the holes in this thin aluminum stock and avoid jagged edges is to first drill a small hole and then enlarge it with a rat-tail file.—W9TUI

### CHASSIS LAYOUT TRICK

Here is a trick that I think will save you time when you do that next layout job. Procure some cross-section paper (graph paper) from a stationery

store, and fasten this paper to the bare chassis with transparent adhesive tape. Try to get the type of graph paper that is divided by inches and tenths of inches.

The uniform markings on the paper act as a guide so that you can get a uniform layout. Also, you can visualize the size of the space occupied by various components, and avoid a crowded layout. The paper also protects the chassis from fingermarks and oil from your tools.—W1RQC

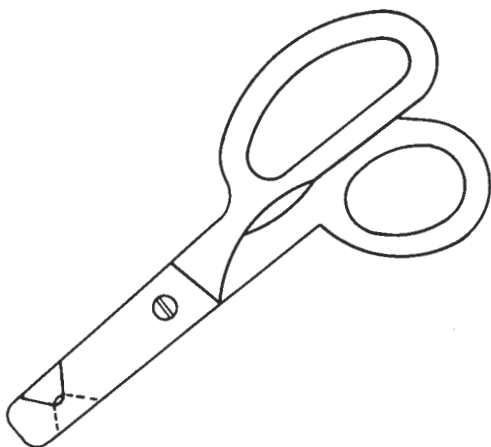

Fig. 6. Scissors arranged as per suggestion of W8TIC

## Notes on Designing a Power Supply

This is not intended to be a deep technical discussion, but merely a clear, easy-to-follow description of how to select the right components for a power supply. For the reasons behind the statements about to be made you are referred to any amateur handbook. A power supply circuit is relatively simple, but unless certain fundamental rules are observed, the results obtained will not always be satisfactory.

The first two questions to be answered are: 1) do I need exceptionally good regulation? and, 2) how much ripple voltage can I tolerate? Both of these questions can be answered simply if you know the use to which the power supply will be put.

You will need good regulation if the current drain from the power supply is variable; that is, subject to change while in use. Examples of this sort of service would be power supplied to a class-B modulator stage, to class-B linear amplifier stages, or to the stages in a c.w. transmitter, including the keyed stage. On the other hand, if you are supplying voltage to a buffer stage in a 'phone transmitter, then regulation is not too important, because the current drain will be constant.

The question on ripple is just as easy to answer. For any stage in a c.w. transmitter, 5% ripple can be tolerated. For any stage in the r.f. section of a 'phone rig, except the modulated stage, 5% ripple is satisfactory. However, for the modulated stage itself, the power supply should have 0.25% ripple, or less. The audio stages should similarly have less than 0.25% ripple applied to them, except for the class-B modulator, where 5% ripple is satisfactory. In the case of high-gain audio amplifiers, as low as 0.1% ripple is desirable. This figure of 0.1% ripple applies also to power supplies used with receivers.

The ripple requirement determines the filtering necessary. A one-section filter ordinarily is used to reduce the ripple to 5%, but it is not usually economical to try to get much more reduction than that with a one-section filter. Considering full-wave circuits, where the ripple frequency is 120 cycles, five-percent ripple will be obtained when the product of inductance (in henrys) and capacitance (in mfd) equals twenty. A choke input filter with a 10-henry choke and a 2 mfd condenser will give 5% ripple. To achieve further ripple reduction a multiple-section filter is usually employed. A two-section filter of this sort might consist of an input choke, a condenser, a second choke, and another condenser. For example, if you added another 10-henry choke and a 4-mfd condenser to the filter constants given above, the overall filtering action would reduce the ripple to less than 0.2 percent. (Most handbooks tell you how to compute the ripple for other combinations of L and C.)

The regulation of a power supply, that is, the relation between the output voltage at no load and at full load, is determined almost entirely by the inductance of the input choke. The *minimum* value of inductance at this point which prevents the d.c.

output voltage from rising above the average value of the a.c. voltage being rectified is called the *critical inductance*. Conservative design indicates the use of a choke having a value at least twice the critical inductance.

The critical inductance, in henrys, for 120 cycle ripple is determined by dividing the load resistance by 1000. For example, a load of 1000 volts at 40 mils (the bleeder current, or minimum current only) gives a load resistance of 25,000 ohms. In this case, an input choke of 50 henrys would give excellent regulation characteristics (twice the 25 henrys critical inductance).

If you find that this value of inductance is too great a drain on the pocketbook, a lower value can be used if the bleeder current is increased. For example, an 80 mil bleeder will result in a critical inductance of 12.5 henrys, so that a 25-henry choke would be desirable. Note that the input choke need have this high value of inductance only at the minimum (bleeder) current. Swinging chokes are widely used for this reason.

Check the value of the bleeder in your present power supply, and see if you have one which is drawing sufficient current!

At this point in your thinking you are ready to select components for your power supply. You select an input choke of the calculated value with sufficient current rating to handle both the bleeder current and the useful load current. Next, select a condenser to give the required reduction in ripple when used with the input choke already selected (choose these values to avoid resonance at the ripple frequency—your handbook gives details). A second section can be selected if ripple requirements demand it. The bleeder resistor is determined as mentioned in the previous paragraph.

Next, compute the voltage drop across the choke or chokes, and add to this the voltage drop across the rectifier tube. Now add the desired output voltage, and multiply by 1.1 to get the value of a.c. r.m.s. voltage required from center-tap to one side of the transformer. For example, if the load current is 200 mils, the bleeder current 40 mils, and desired output voltage 1000 volts, compute the drop across the chokes due to 240 mils current (say this is 24 volts), add tube drop (say 15 volts for mercury-vapor tubes), and you get 1039 volts. Multiply by 1.1 and you get 1143 volts. You therefore want a transformer with a secondary voltage rating of 1143-0-1143, and with a current rating of approximately 250 mils. This transformer will supply a d.c. output voltage of 1000 volts and a useful current of 200 mils, in the power supply you just calculated.

Some transformers are rated for *d.c. output voltage* rather than for a.c. voltage. In this case the transformer manufacturer has already calculated the d.c. output voltage from a typical filter system. Just make certain that you know how the transformer is rated before you use it.

— Lighthouse Larry

# **SWEEPING** *the* **SPECTRUM**



I recently received a very nice letter from W9ONY, president of the Milwaukee Radio Amateurs' Club, in which Fred expressed his appreciation to G.E. for the film *And a Voice Shall Be Heard*. To quote him: "The membership was thrilled over it and it certainly presents a vital message to all." This film, prepared by The March of Time for G.E., gives the story of civil defense in Onondaga County, New York. The part of the radio amateur is very well presented.

If you would like to arrange to show this film to your local club, a copy may be borrowed from one of the eighteen G.E. film libraries throughout the country. You can get the address of the nearest library by writing to your local G.E. office, or, by dropping me a note. The running time is approximately 20 minutes, and the film is 16 mm. sound. If you think your local civil defense office would be interested, ask one of the officials to drop in at your showing—he might wish to arrange to borrow the film for a general civil defense meeting.

\*\*\*

Have you seen any lampshades around your town? The type I'm talking about wouldn't be inside a house, but would be mounted outside on a steel pole in some clear area. If there aren't any lightbulbs inside these lampshades, then the chances are that they are special radiation detectors, made to determine quickly and accurately the position of an atomic bomb explosion.

These radiation lampshades have been designed by a group of people in Schenectady, many of them employed in General Electric Co. The Schenectady County Civil Defense authorities have already installed a complete system of these detectors in the County.

The lampshade determines the height at which a bomb has exploded and the position of ground zero—the point directly under the blast. The device is made of sheet metal, about a foot in diameter, smaller at the top than at the bottom, and is painted white inside and out. On the inside, numbered vertical lines and horizontal lines are painted. A pointed brass rod projects upward inside the lampshade.

During an actual bombing, intense heat radiation would scorch the inside painted surface in relation to the direction of the burst, forming an unscorched shadow of the vertical rod. The position of the shadow gives information as to direction and height of the bomb burst. Readings taken from several lampshades can be correlated to give exact information.

Why talk about lampshades? Well, it seems to me that a couple of ham mobile rigs would be the ideal way to get the information back to Control Center in a hurry, where the plotting can be accurately completed.

\*\*\*

Speaking of red-hot temperatures, the engineers in the Schenectady vacuum-tube plant recently had a problem which electronics solved for them. In making ignitrons (a special type of heavy-duty rectifier) it is necessary to heat some of the tube parts to rather high temperatures. However, just any temperature won't do, and the exact temperature is important to tube quality.

The solution was found in a G-E electric eye unit, which controls the temperature of the glowing graphite crucibles as they are heated to a temperature of approximately 3500 degrees Fahrenheit. At this temperature the graphite is a dazzling white color. The control unit is able to maintain temperatures in this range with an accuracy of 15 degrees.

You'll probably never want to know the temperature of the anode in your final tubes, but if they are running in the red-hot to white-hot range, you could read and control this temperature by using this G-E device.

\*\*\*

A news release that passed over my desk recently told of the completion of a number of radar picket posts that have been installed by G.E. for the U.S. Air Force. The location and number of these posts is secret, according to G-E officials, but some of the unclassified information is quite interesting.

These radar installations are capable of detecting aircraft at long range, and are now protecting the U.S. and Canada against sneak enemy air attack. Installations in the Arctic regions are housed in rubberized fabric "radomes," supported entirely by air pressure, and resembling huge pumpkins.

An estimated 400 men are required to operate each installation, on a 24-hour basis. Imagine what a ham could do with an arrangement of that sort, especially if it was designed for DX work! With 400 helpers, one ought to be able to work at least 100 countries in an afternoon. Of course, you'd have to call it a multiple-operator station!

It's a comforting thought to know that these radar installations are now at work protecting our borders—serving as the outposts of our civil defense organization. What are you doing for civil defense these days?

—*Lighthouse Larry*

## GERMANIUM DIODE

### GENERAL DESCRIPTION

The IN48 is a general-purpose germanium diode which exhibits a medium back-resistance characteristic and has a medium inverse voltage rating. The

Mounting Position . . . . . Any

IN48 is designed for most low-current power-rectification applications such as isolation, clipping, switching, and meter rectification.

### PHYSICAL DIMENSIONS

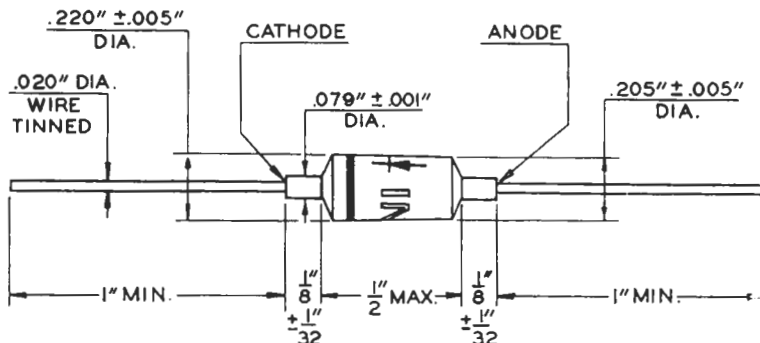

### MAXIMUM RATINGS

AT AMBIENT TEMPERATURE OF +25 CENTIGRADE

Peak Inverse Voltage . . . . .	85	Volts
Continuous Inverse Voltage . . . . .	70	Volts
Average Rectified Current . . . . .	50	Milliamperes
Peak Rectified Current . . . . .	150	Milliamperes
Surge Current for 1 Second . . . . .	400	Milliamperes
Ambient Temperature Range . . . . .	-50 to +75	Centigrade



# Ham News

Available FREE from

G-E Electronic Tube Distributors

Printed in U.S.A.

## A Bi-monthly Publication

TUBE DEPARTMENT, ELECTRONICS DIVISION

# GENERAL ELECTRIC

SCHENECTADY 5, N. Y.

(In Canada, Canadian General Electric Company, Ltd., Toronto, Ont.)

GEO. H. FLOYD, W2RYT—EDITOR

FROM: